

## APPAREIL DE TRACTION À CÂBLE GRIPPER / REF : GRIP

Capacité	800 kg / 1600 kg / 3200 kg
Référence	GRIP

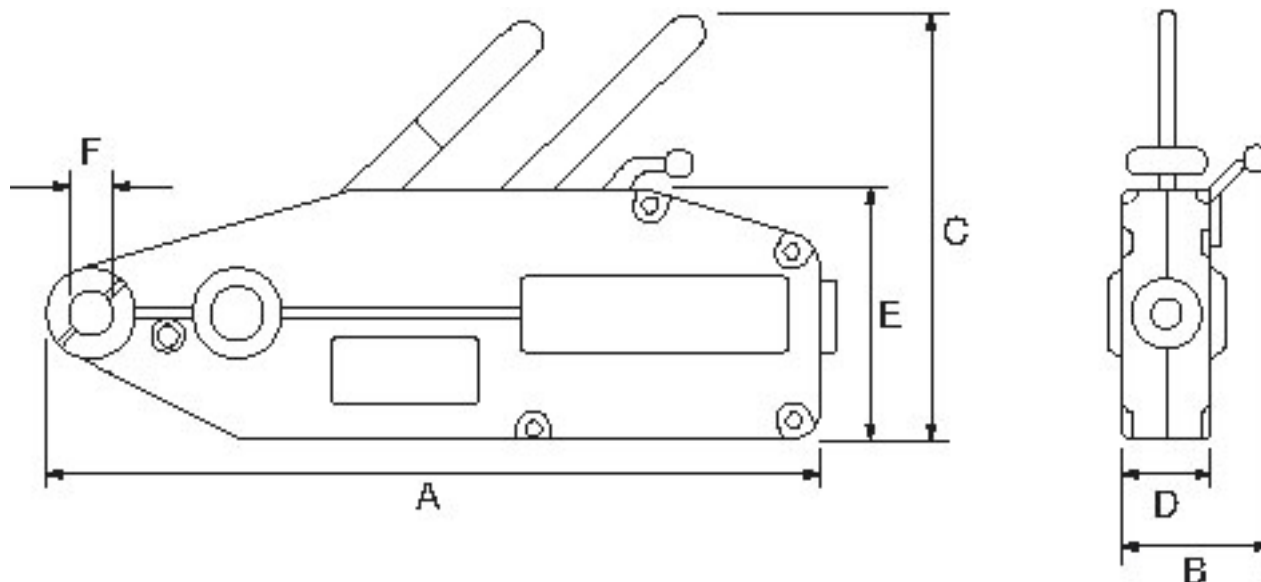

Type	CMU (kg)	Effort sur chaîne de manœuvre max. (kg)	Longueur du levier (mm)	Course par tour du levier (mm)	Diamètres câble (mm)	Poids (kg)
GRIP-08	800	28	740	52	8.4	6.1
GRIP-16	1600	41	1120	55	11.0	11.9
GRIP-32	3200	44	1120	28	16.1	21.1

Type	A (mm)	B (mm)	C (mm)	D (mm)	E (mm)	F (mm)
GRIP-08	425	65	230	59	170	22.0
GRIP-16	545	95	270	72	190	24.5
GRIP-32	660	116	325	94	220	29.5



GRP-08



GRP-16



GRP-32